



Designation: D402/D402M – 24

American Association State  
Highway and Transportation Officials Standard  
AASHTO No.: T78



27/74 (88)

## Standard Test Method for Distillation of Cutback Asphalt<sup>1</sup>

This standard is issued under the fixed designation D402/D402M; the number immediately following the designation indicates the year of original adoption or, in the case of revision, the year of last revision. A number in parentheses indicates the year of last reappraisal. A superscript epsilon ( $\epsilon$ ) indicates an editorial change since the last revision or reappraisal.

### 1. Scope

1.1 This test method covers a distillation test for cutback asphalts.

1.2 The values stated in either SI units or inch-pound units are to be regarded separately as standard. The values stated in each system may not be exact equivalents; therefore, each system shall be used independently of the other. Combining values from the two systems may result in nonconformance with the standard.

1.3 *This standard does not purport to address all of the safety concerns, if any, associated with its use. It is the responsibility of the user of this standard to establish appropriate safety, health, and environmental practices and determine the applicability of regulatory limitations prior to use.*

1.4 *This international standard was developed in accordance with internationally recognized principles on standardization established in the Decision on Principles for the Development of International Standards, Guides and Recommendations issued by the World Trade Organization Technical Barriers to Trade (TBT) Committee.*

### 2. Referenced Documents

2.1 *ASTM Standards:*<sup>2</sup>

[D86 Test Method for Distillation of Petroleum Products and Liquid Fuels at Atmospheric Pressure](#)

[D370 Practice for Dehydration of Oil-Type Preservatives](#)

[D3666 Specification for Minimum Requirements for Agencies Testing and Inspecting Road and Paving Materials](#)

[D4311/D4311M Practice for Determining Asphalt Volume Correction to a Base Temperature](#)

[D8055 Guide for Selecting an Appropriate Electronic Thermometer for Replacing Mercury Thermometers in D04 Road and Paving Standards](#)

[E1 Specification for ASTM Liquid-in-Glass Thermometers](#)  
[E77 Test Method for Inspection and Verification of Thermometers](#)

[E230/E230M Specification for Temperature-Electromotive Force \(emf\) Tables for Standardized Thermocouples](#)

[E644 Test Methods for Testing Industrial Resistance Thermometers](#)

2.2 *IEC Standards:*<sup>3</sup>

[IEC 60584 Thermocouples—Part 3: Extension and Compensating Cables—Tolerances and Identification System](#)

### 3. Summary of Method

3.1 Two hundred milliliters of the sample are distilled in a 500 mL flask at a controlled rate to a temperature in the liquid of 360 °C [680 °F], and the volumes of distillate obtained at specified temperatures are measured. The residue from the distillation, and also the distillate, may be tested as required.

### 4. Significance and Use

4.1 This procedure measures the amount of the more volatile constituents in cutback asphalt. The properties of the residue after distillation are not necessarily characteristic of the asphalt used in the original mixture, nor of the residue which may be left at any particular time after field application of the cutback asphalt. The presence of silicone in the cutback asphalt may affect the distillation residue by retarding the loss of volatile material after the residue has been poured into the residue container.

NOTE 1—The quality of the results produced by this standard are dependent on the competence of the personnel performing the procedure and the capability, calibration, and maintenance of the equipment used. Agencies that meet the criteria of Specification [D3666](#) are generally considered capable of competent and objective testing, sampling, inspection, etc. Users of this standard are cautioned that compliance with

<sup>1</sup> This test method is under the jurisdiction of ASTM Committee [D04](#) on Road and Paving Materials and is the direct responsibility of Subcommittee [D04.46](#) on Durability and Distillation Tests.

Current edition approved Jan. 15, 2024. Published February 2024. Originally approved in 1934. Last previous edition approved in 2014 as D402/D402M – 14, which was withdrawn in 2023 and reinstated January 2024. DOI: 10.1520/D0402\_D0402M-24.

<sup>2</sup> For referenced ASTM standards, visit the ASTM website, [www.astm.org](http://www.astm.org), or contact ASTM Customer Service at [service@astm.org](mailto:service@astm.org). For *Annual Book of ASTM Standards* volume information, refer to the standard's Document Summary page on the ASTM website.

<sup>3</sup> Available from International Electrotechnical Commission (IEC), 3, rue de Varembe, 1st floor, P.O. Box 131, CH-1211, Geneva 20, Switzerland, <https://www.iec.ch>.

Specification D3666 alone does not completely ensure reliable results. Reliable results depend on many factors; following the suggestions of Specification D3666 or some similar acceptable guideline provides a means of evaluating and controlling some of those factors.

**5. Apparatus**

5.1 *Distillation Flask*, 500 mL side-arm, having the dimensions shown in Fig. 1.

5.2 *Condenser*, standard glass-jacketed, of nominal jacket length from 200 to 300 mm [7.9 to 11.8 in.] and overall tube length of  $450 \pm 10$  mm [ $17.7 \pm 0.4$  in.] (see Fig. 3).

5.3 *Adapter*, heavy-wall (1 mm [0.04 in.]) glass, with reinforced top, having an angle of approximately  $105^\circ$ . The inside diameter at the large end shall be approximately 18 mm [0.7 in.], and at the small end not less than 5 mm [0.2 in.]. The lower surface of the adapter shall be on a smooth descending curve from the larger end to the smaller. The inside line of the outlet end shall be vertical, and the outlet shall be cut or ground (not fire-polished) at an angle of  $45 \pm 5^\circ$  to the inside line.

5.4 *Shield*, steel, lined with 3 mm [0.1 in.] fireproof insulation and fitted with transparent mica windows, of the form and dimensions shown in Fig. 2, used to protect the flask from air currents and to reduce radiation. The cover (top) shall be made in two parts of 6.4 mm [0.25 in.] fireproof insulation.

5.5 *Shield and Flask Support*—Two  $15 \text{ cm}^2$  [ $2.3 \text{ in.}^2$ ] sheets of 16-mesh Chromel wire gauze on a tripod or ring.

5.6 *Heat Source:*

5.6.1 Adjustable Tirrill-type gas burner or equivalent.

5.6.2 An electric heater with a shield and support. The shield and support shall be a refractory with an opening of 79 mm [3.1 in.], with the upper surface beveled to 86 mm [3.4 in.] to accommodate the specified 500 mL flask. When the flask is placed on the refractory, there should be a distance of approximately 3 mm [0.1 in.] between the bottom of the flask and the heating elements.

5.7 *Receiver*—A standard 100 mL graduated cylinder or a 100 mL Crow receiver as shown in Fig. 4 of this test method.

NOTE 2—Receivers of smaller capacity having 0.1 mL divisions may be used when low volumes of total distillate are expected and the added accuracy required.

5.8 *Residue Container*—A seamless metal container with slip-on cover  $75 \pm 5$  mm [ $3.0 \pm 0.2$  in.] in diameter and  $55 \pm 5$  mm [ $2.2 \pm 0.2$  in.] in height.

5.9 *Thermometer*—A thermometer for measuring the temperature of the sample during distillation. The thermometer shall have a measurement temperature range of 150 to 400 °C [300 to 760 °F] and an accuracy of at least  $\pm 1.5$  °C [ $3$  °F] and shall be one of the following (see Note 3):

5.9.1 An 8C [8F] thermometer which conforms to the requirements of Specification E1. Calibrate the thermometer in accordance with one of the methods in Test Method E77.

5.9.2 A platinum resistance thermometer (PRT) readable to the nearest 0.5 °C [ $1$  °F], with a Pt 100 Class A tolerance rating and either a three or four-wire configuration and an overall sheath length at least 50 mm [2 in.] greater than the immersion depth. Standardize the PRT system (probe and readout device) in accordance with Test Methods E644. Corrections shall be applied to ensure accurate measurements within 1.5 °C [ $3$  °F]. The PRT meter shall display temperature to the nearest 0.5 °C [ $1$  °F].

5.9.3 A Class 1, Type T, K, or J thermocouple (Specification E230/E230M, IEC 60584) with a sufficient length of wire that allows the meter to be placed away from the heat source and with covering that can withstand exposure to the upper temperature limit, and a sensor-compatible meter that can display the temperature the nearest 0.5 °C [ $1$  °F]. Corrections shall be applied to ensure accurate measurements within 1.5 °C [ $3$  °F].

NOTE 3—Guide D8055 provides additional guidance on selecting appropriate alternatives to mercury-in-glass thermometers.

**6. Hazards**

6.1 **Warning**—Mercury has been designated by the United States Environmental Protection Agency (EPA) and many state agencies as a hazardous material that can cause central nervous system, kidney, and liver damage. Mercury, or its vapor, may be hazardous to health and corrosive to materials. Caution should be taken when handling mercury and mercury-containing products. See the applicable product Material Safety Data Sheet (MSDS) for details and EPA’s website—

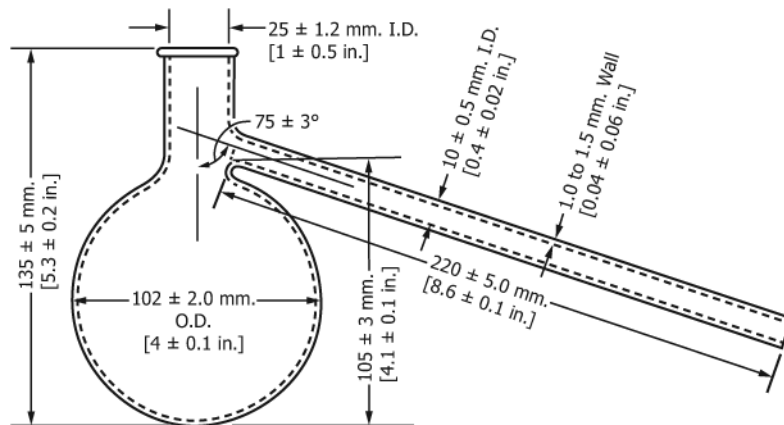

FIG. 1 Distillation Flask